

## Low Voltage Nail-on Mounting Brackets

### Single & Double-gang Nail-on Mounting Brackets

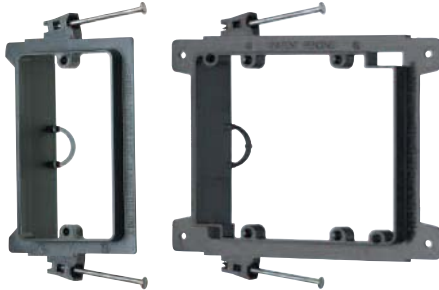

#### Product Description

Non-metallic, Low Voltage Nail-on Mounting Brackets designed for installation of Class 2 wiring offer the fast, easy, and cost-effective way to install CAT5e, fiber optic, and other communications cabling in new construction. These low voltage brackets are made of non-conductive plastic to protect cable from damage.

#### Features

- Available in single and double gang styles
- Built-in loop to tie off cable
- Eliminates pushback
- Comes with nails in place, ready to install
- Installs in less time than other mud rings

#### Specifications

Materials ----- High impact, UL 94V-0 rated thermoplastic

Safety ----- UL, CSA

#### Dimensions

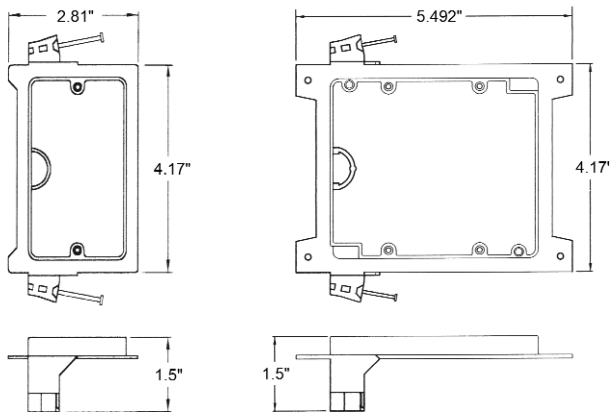

Part #	Description	Qty
LVN1	Single-gang, low-voltage nail-on mounting bracket	50/box
LVN2	Double-gang, low-voltage nail-on mounting bracket	25/box

Specifications subject to change without notice. Copyright 2010. Original: 04/10