

HPNA3 over Coax Gigabit Ethernet Bridge

User's Guide

V1.0

INTRODUCTION

This HCNA (HomePNA3.1 over Coax) to Ethernet bridge connects any Ethernet device to a high speed access device or to a LAN for Internet access. This bridge brings you the newest Ethernet compatible technology that uses the coaxial cable as the network's physical wiring thereby eliminating the need to install new wiring. It is designed to operate on the coaxial TV cable installed in homes.

This bridge allows you to connect PCs and Ethernet enabled devices, such as Switch, HUB and printers, to a Home Networking LAN by simply plugging into the existing coaxial F-Type connector.

Features

- Plug & Play
- Using existing coaxial TV cable to build a home network
- Shares Internet access and streaming video
- 1 port connection compliant with HomePNA 3.1 over Coax (HCNA) standard
- 2 Standard 10/100/1000BaseT Gigabit Ethernet ports for connecting to Ethernet or cable modem
- MDI/MDIX Auto Crossover Support
- QoS Priority Mapping Support
- Configurable QoS, TagVLAN, Bandwidth Control
- Statistics and Status Information Support

HARDWARE INSTALLATION

Parts Names and Functions

LED Indicators on the Rear Panel

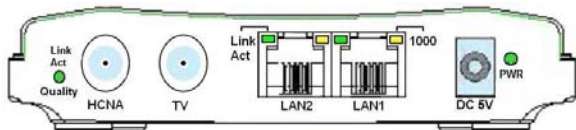

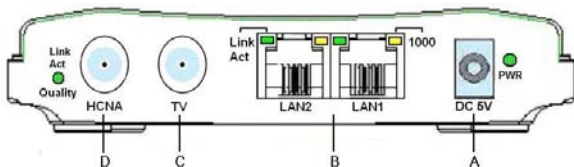

Port	LED	Status		
		ON	Flashing	OFF
DC 5V	PWR	Powered by DC5V	N/A	Not powered
LAN1	Link Act	Link	Receive or Transmit	Disconnect or Link fail
	1000	1000Mbps	N/A	10Mbps or 100Mbps
LAN2	Link Act	Link	Receive or Transmit	Disconnect or Link fail
	1000	1000Mbps	N/A	10Mbps or 100Mbps
HCNA	Link Act	Link	Receive or Transmit	Disconnect or Link fail
	Quality	Green:High Orange:Medium Red:Low		

Ports on the Rear Panel





	Port Name	Type	Functions
A	DC 5V	DC	Connect to the power adapter plug.
B	LAN1/LAN2	RJ-45	Connect to Ethernet port on FTTH or xDSL Modem or Switch for Internet Access.
C	TV	F	Connect to TV
D	HCNA	F	Connect to HCNA devices

Essential Hardwares

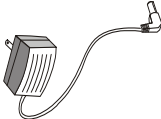
Items Included	Description	Purpose
	HCNA to Ethernet Bridge	Main Unit
	Coaxial Cable (F-Type/ RG-59U)	Connects from HCNA port to coax F-Type connector on the wall outlet.

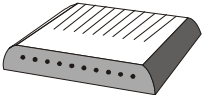
	<p>CAT5 Ethernet cable</p>	<p>Connects from LAN port to Ethernet enabled devices as PC or STB</p>
	<p>DC5V Power adapter</p>	<p>Connects from Power port of the main unit into a wall outlet</p>

<p>Additional Items (Not Included)</p>	<p>Description</p>
	<p>A well-installed WAN environment (Cable Modem or xDSL Modem)</p>
	<p>A well-installed LAN environment</p>

Hardware Connections

1. Select a convenient location for the bridge near the PC or Ethernet device to which it will be connected. The bridge should be kept away from excessive heat.
2. Using one coaxial cable to connect the **HCNA** port to F-Type connector on the wall. Using another coaxial cable to connect the other F-type **TV** port to TV set (optional).

3. Connect the **LAN1/LAN2** port to your Ethernet-equipped device.
4. Connect the power adapter to the **DC5V** port into a wall outlet.

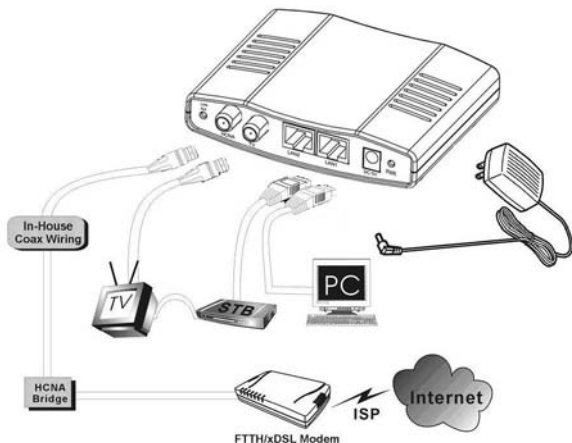

The figure above shows how to connect an xDSL modem to a home coaxial cable network. Follow the same steps to connect any Ethernet device such as a HUB or printer, to a coaxial cable network.

Now you should have connected the **LAN** port, **HCNA** port and the **DC 5V** port to the appropriate devices or lines. LED will be as:

PWR	ON
LAN Link/Act	ON
HCNA Link/Act	ON (Green or Orange)

For more information on LEDs, see section entitled ["LED Indicators on the Rear Panel"](#)

TROUBLESHOOTING

The bridge has been designed to be a reliable and easy to use connection device. Please refer to the list below to aid in troubleshooting.

The Power (green PWR) LED is off.

- *Make sure the power adapter is properly plugged into a live electrical outlet.*

The LAN(Ethernet) LED is off.

- *Make sure the connection to LAN port is secure.*
- *The Ethernet device to which you are connected should be powered on and properly configured.*

The HCNA Link/Act/Quality LED is off or red

- *Make sure the connection to HCNA port is secure.*
- *HCNA device to which you are connected should be powered on and properly configured.*
- *Make sure the quality of coaxial connector and cable is good.*

SPECIFICATIONS

Standards

- IEEE 802.3 10BaseT Ethernet
- IEEE 802.3u 100BaseT Fast Ethernet
- IEEE 802.3ab 1000BaseT Gigabit Ethernet
- HomePNA 3.1 over Coax compliant

Data Rates

- HCNA: 256 Mbps maximal
- Ethernet: 10/100 /1000 Mbps

Transmission Range

- HCNA : Up to 50dB attenuation
- Ethernet: 100 meters maximum

Power Consumption

- 5V DC, Less than 4 watt

Certifications

- CE, FCC Part 15

LEDs

- Power
- Ethernet Link/Activity/Speed
- HCNA Link/Activity/Quality

Connectors

- Two F-Type connectors, one for connecting with HCNA device, and one for TV Bypass
- Two RJ-45 for 10/100/1000Mbps Ethernet

Cables

- HCNA: F-Type RG-59U coaxial cable
- Ethernet: CAT5E or better UTP