

SUTTLE

www.suttleonline.com

1-800-852-8662

CABLE SERIES: (red compression ring) rg59/rg59 quad
(green compression ring) rg6/rg6 quad

TOOL: SL-TOOL

1. Use a 1/4" x 1/4" cable prep tool. Assure that the braid is folded back onto the jacket as shown in Figure 1. If a color ring is going to be placed on the connector, slide it onto the cable before assembling the connector onto the cable

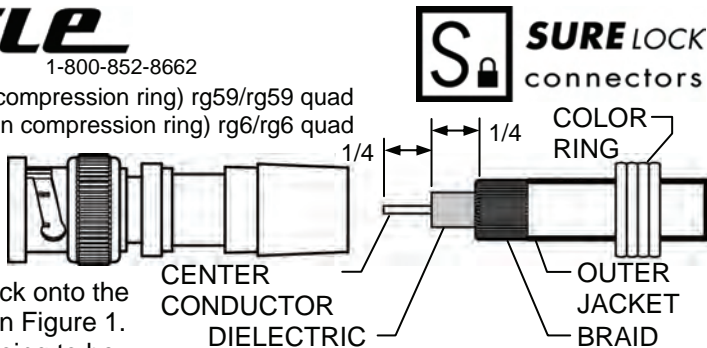
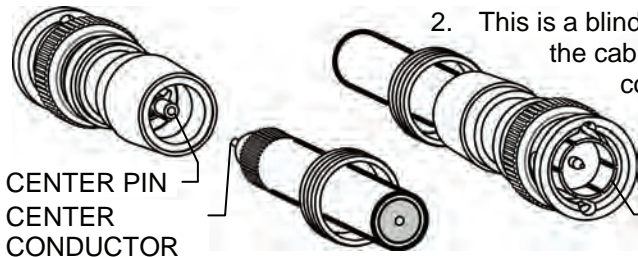

Figure 1
Cable prep



CENTER PIN
CENTER
CONDUCTOR

2. This is a blind entry connector. Once the cable is fully inserted into the connector, the center pin will align with the front surface of the inner ring as shown in Figure 2.

CENTER PIN FLUSH
WITH INNER RING

Figure 2

3. No tool tip is required for the SL-TOOL when using this connector. Place the connector and cable into the tool as shown in Figure 3. The top of the connector will fit into the spring clip on the plunger head of the SL-TOOL and the crimp ring of the connector will rest against the cable yoke. The connector must be parallel to the body of the tool.

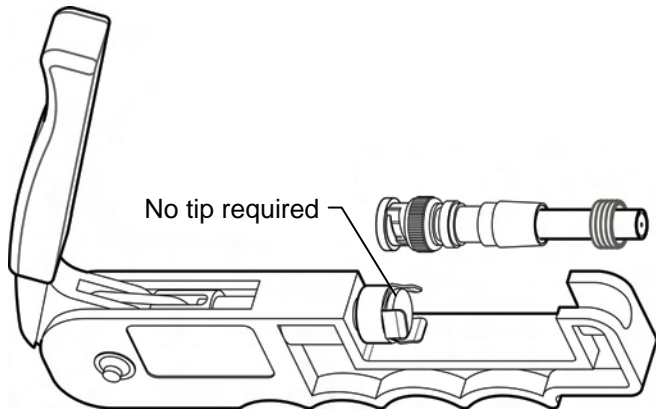

4. Press the tool until the handle closes completely against the body of the tool.

Figure 3 SL-TOOL