

# SUTTLE

www.suttleonline.com

1-800-852-8662

CABLE SERIES: (red compression ring) rg59/rg59 quad  
(green compression ring) rg6/rg6 quad

TOOL: SL-TOOL

1. Use a 1/4" x 1/4" cable prep tool. Assure that the braid is folded back onto the jacket as shown in Figure 1.

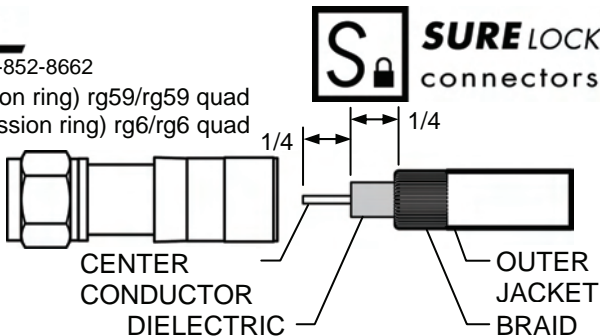

**Figure 1** Cable prep

2. Insert the prepared cable end into the connector. Push the center conductor into the plastic guide pin and push the cable until the dielectric is flush with the inside surface of the nut. See Figure 2. Discard the guide pin after the cable has been installed.

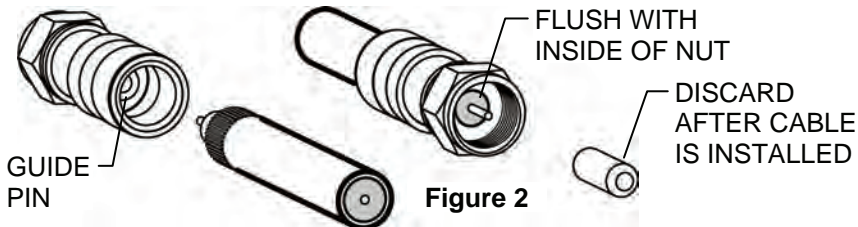

**Figure 2**

3. Snap the appropriate tool tip into the spring clip on the plunger head of the SL-TOOL (shown in Figure 3). Place the connector and cable into the tool as shown in Figure 3. The front of the connector must be flat against the tool tip and the crimp ring of the connector will rest against the cable yoke. The connector must be parallel to the body of the tool.

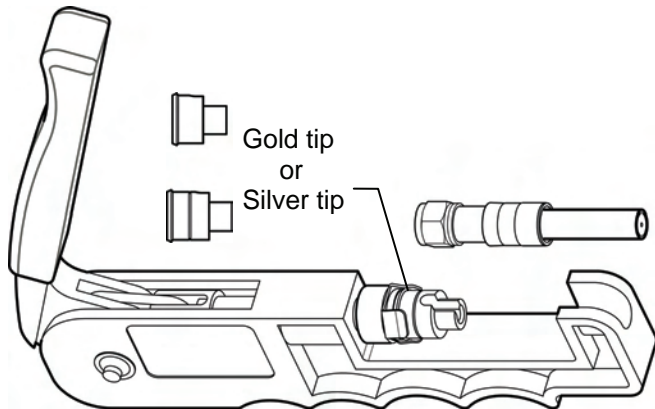

4. Press the tool until the handle closes completely against the body of the tool.

**Figure 3** SL-TOOL