

SUTTLE

SAM-MP6 6 Line Multi-Provider module

User Guide

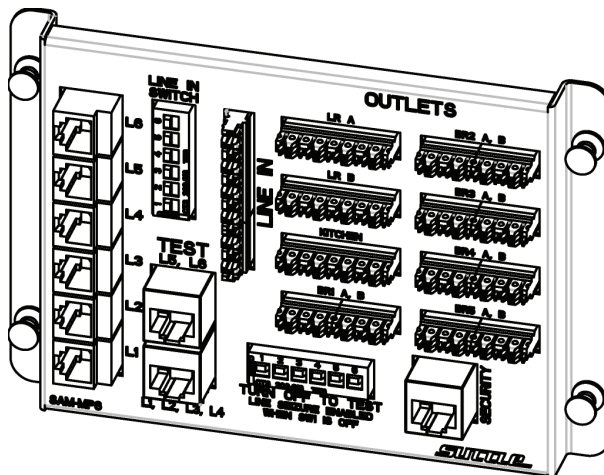

1. Introduction

Features

- Conforms to UL standards.
- Accommodates up to 6 Telephone service lines.
- Alarm interface is configured for use on service line 1.
- Centralized test port, to verify incoming phone service.
- Supports 5 private lines and 1 common line for a shared residence.
- Enables customer to select from multiple service providers on a per line basis.
- Installer-friendly push-lock pin mounting.

Package Contents

- 6 Line Multi-Provider Module
- Designation label
- User's Guide

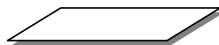

Designation label

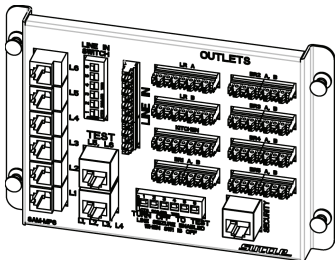

Multi-Provider
Module



User's Guide

Compare the contents of your SAM-MP6 with the checklist above. If any item is missing or damaged, please contact your local dealer for service.

2. Module Installation

Mounting:

Align the mounting pins with the grid holes on the back of the enclosure. With the mounting pin plungers in the “out” position, press the unit into the grid in the desired location, secure by pushing the plungers in.

Incoming service lines:

Run twisted pair cable to the 110 IDC connector labeled “**LINE IN**” on the Multi-Provider Module from the primary service provider’s demarcation point.

110 IDC Termination Procedure

Strip 3 in. of outer jacket from the cable. Place wires into proper slots according to selected configuration. Starting at the blue-position of the IDC, begin with the white wire of each pair as you progress to the brown-position on the IDC as shown below. Press wires into slots with punch tool. Trim excess wire with diagonal cutter.

NOTE: one pair of wires corresponds to each line from the phone company. (Line 1=blue, Line 2=orange, Line 3=green, Line 4=brown, Line 5=slate, Line 6=red).

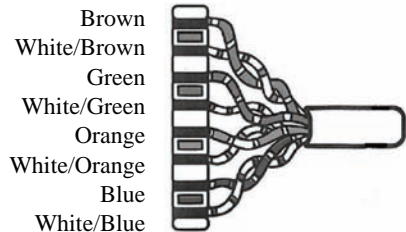

Secondary Provider Input

Use the “**LINE IN SWITCH**” to turn off the primary provider prior to connecting a secondary provider. Connect line in jacks (**L1, L2, L3, L4, L5, L6**) on the SAM-MP6 to secondary provider equipment or to the SAM-MPP using standard telephone line cords.

Premise wiring:

Run twisted pair cable from the numbered 110 IDC's to the telephone outlets throughout the premise. Follow 110 IDC Termination Procedure above. Record wiring information on the designation label and attach to the enclosure cover.

Testing:

To test the incoming service lines, disconnect the premise wiring by selecting the OFF position for all lines using the test switches (located on the right side of the “**TEST**” jacks). Disconnect the jumper cord from the “**SECURITY**” jack, if present. Then, plug the tester into the “**TEST**” jacks to verify phone service. Reposition test switches to the ON position to restore service to the distribution ports, follow directions below for security interface.

Note: Use a qualification tester for testing this bridged voice distribution module.

Alarm Interface connection:

The Multi-Provider Module features a security interface port which may be connected to a security system; in an emergency situation, the security system can over-ride telephone service on **LINE 1** when the alarm is activated. Connect 8 conductor cord from alarm dialer to the “Security” port on the Multi-Provider module. SW1 must be in the off position to allow line seizure.

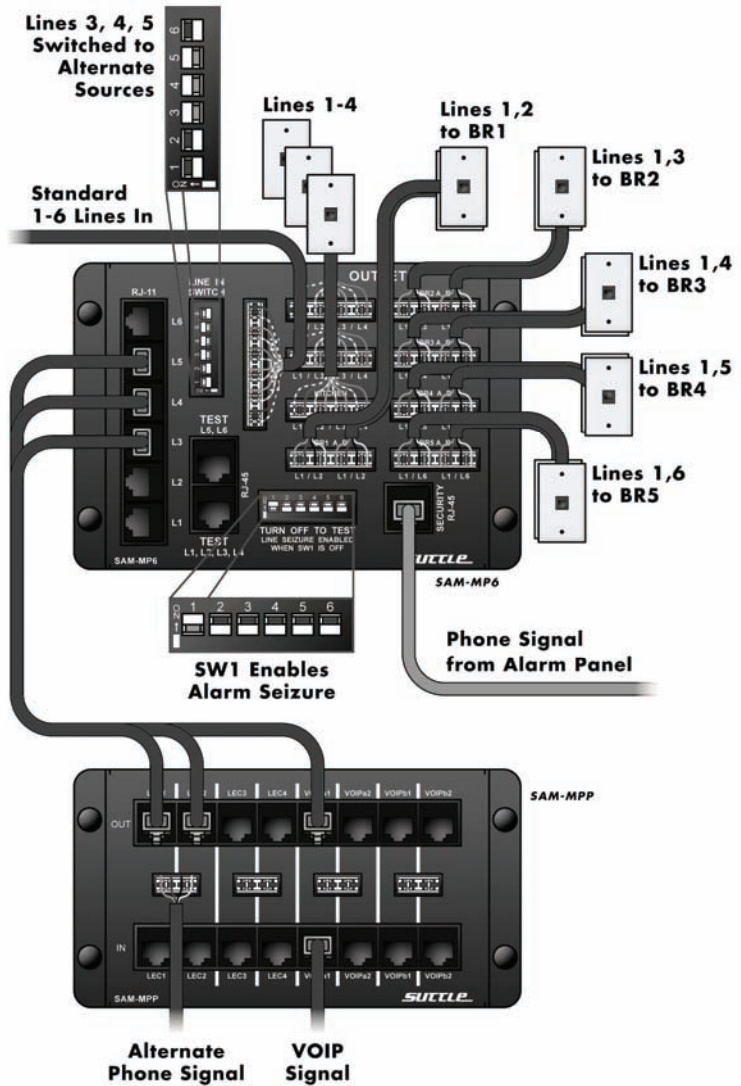

Important Information:

- Read and understand all instructions. Follow all warnings and instructions marked on the product.
- Do not use this product near water,--e.g., near a bath tub, wash basin, kitchen sink, wet basement, or near a swimming pool.
- Never push objects of any kind into this product through openings, as they may contact dangerous voltages.
- SAVE THESE INSTRUCTIONS.

Safety Information:

- Never install communications wiring or components during a lightning storm.
- Never touch uninsulated wires or terminals unless the wiring has been disconnected at the network interface.
- Never install communications components in wet locations unless the components are designed specifically for use in wet locations.

100701-00 Rev. B

1001 East Hwy 212
Hector, MN 55342
www.suttlesoho.com

Toll Free: 1-800-852-8662
Local: 1-320-848-6711
Fax: 1-320-848-2361