

SUTTLE

SAM-SW5U

5-port 10/100 Ethernet Switch

User Guide



1001 East Hwy 212
Hector, MN 55342
www.suttleonline.com

Toll Free: 1-800-852-8662
Local: 1-320-848-6711
Fax: 320-848-2361

1. Introduction

The 5 port 10/100BASE-TX Switch is compact and attractively designed for use within Suttle's *SOHO Access*[™] Enclosure. They are ideal solution for small office or home office network user. The Switches provide wire-speed, Fast Ethernet switching function that allows high-performance, low-cost connection.

The 5 port 10/100BASE-TX Switch will automatically detect the speed of the device that you plug into it to allow you to connect both 10 and 100Mbps device. They feature a store-and forward switching and it can auto-learn and store source address.

Features

- Conforms to IEEE 802.3, 802.3u and 802.3x standard
- 5 10/100Mbase-TX Switch
- Auto MDI/MDI-X on all ports
- N-way auto-negotiation
- IEEE802.3x Flow control
 - Flow control for full duplex
 - Backpressure for half duplex
- Store-and-forward switching architecture
- 1 Mbits memory buffer
- 1K MAC address table

Module Installation

Align the mounting pins with the grid holes on the back of the enclosure. With the mounting pin plungers in the “out” position, press the unit into the grid in the desired location and secure by pushing the plungers in.

Package Contents

- 5 10/100BASE-TX switch on *SOHO Access™* mounting bracket
- 5 CAT5e RJ45 Patch Cords
- DC Power Adapter
- User's Guide



5 port 10/100BASE-TX Switch
(bracket not shown)



5 – CAT.5e Patch Cords, 12in.



DC Power Adapter



User's Guide

Compare the contents of your switch with the standard checklist above. If any item is missing or damaged, please contact your local dealer for service.

2. Hardware Description

This section mainly describes the hardware of the 5-port switch.

The physical dimensions of the 5 10/100BASE-TX SOHO switch is 110mm x 70mm x 19mm (L x W x H) excluding the bracket.

Front Panel

The LED indicators are located on the front panel of the switch. They provide a real-time indication of systematic operation status. The Front Panels 5 10/100BASE-TX SOHO switch is as the following figure shown.

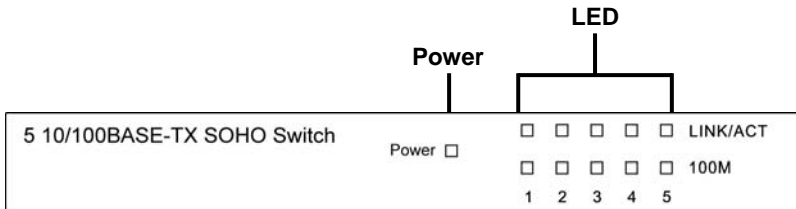

LED	Status	Color	Description
Power	On	Green	The power of the switch is on.
LNK/ACT	On	Green	The port is successfully connecting with the device
	Blinks	Green	The port is receiving or transmitting data.
	Off		No device attached.
100M	On	Green	Link on 100Mbps
	Off		Link on 10Mbps or no device connected.

Rear View

The rear panel of the 5-port switch consists of 5 – 10/100N RJ-45 ports (Auto MDI/MDIX) and one DC power connector.

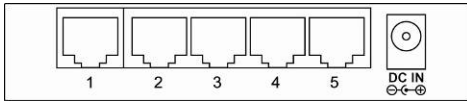

- **RJ-45 Ports:** 5 – 10/100 N-Way Auto MDI/MDIX for 10Base-T or 100Base-TX connections.
- **Auto MDI/MDIX:** It can detect the cable straight connect NIC or cascade to a hub or switch without changing the connector, the maximum distance between the switch and another device is 100 meters.
- **DC Power Connector:** Plug DC Power Adapter's female end into the switch and the male end of the DC Power Adapter into a power outlet. The Adapter supplies the Switch with DC 9V, 700mA.

3. Network Application

This section provides you a few examples of network topology in which the 5-port switch can be used. The switch is designed to be used as a segment switch.

The switch automatically learns node addresses, which are subsequently used to filter and forward all traffic based on the destination address.

Stand Alone

The 5-port switch is designed to be a compact switch, which is an ideal solution for a home or small workgroup. The switch can be used as a standalone switch to which personal computers, servers, and printer servers are directly connected to form small workgroups.

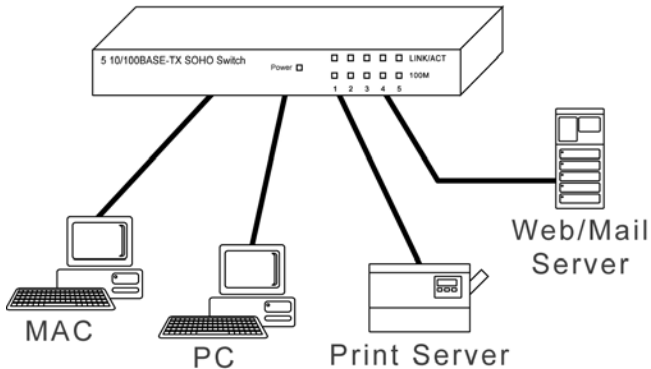

Enlarge Your Network

You can use the any port of the 5-port switch to connect with another hub or switch to interconnect each of your small-switched workgroups to form a large switched network.

You can connect any one switch port to a hub or switch without a crossover cable by the use of the Auto MDI/MDI-X function.

In the below illustration, two switches are used to interconnect two small workgroups. All the devices in this network can communicate with each other. Connecting a server to the switch allows other users to access the server's data.

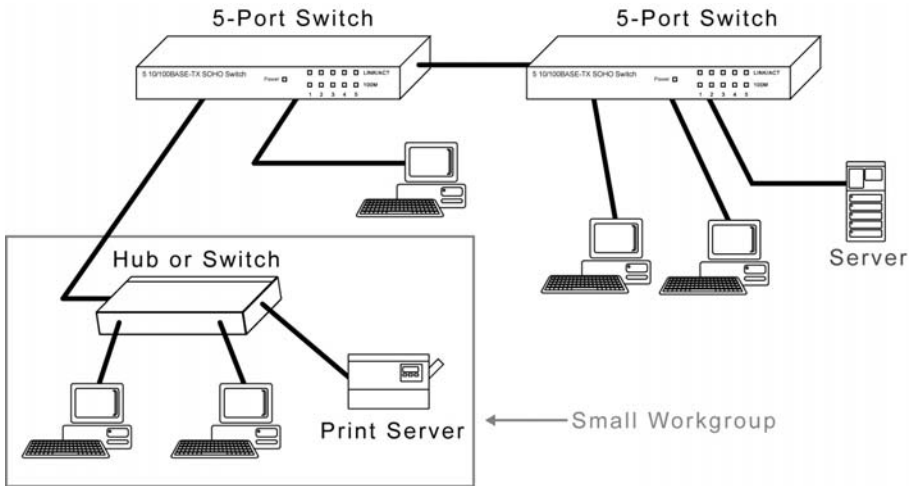

Typical Use in the SOHO Access Enclosure

The Suttle SOHO Access Enclosure is the central distribution device where incoming voice, data, and video are re-distributed throughout the home. The switch is required to distribute the data to outlets through the home. On the next page a diagram shows the typical application of a switch being fed by a DSL modem deployed within the SOHO Access Enclosure.

SOHO Access Enclosure & Modules

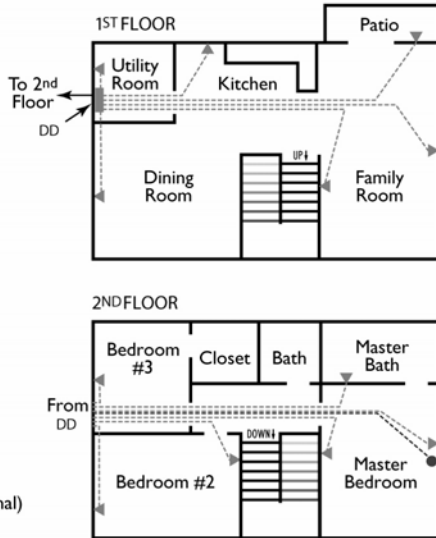
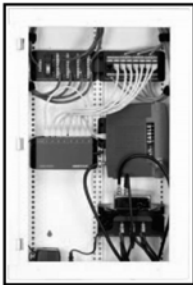

LEGEND:

- ▶ – Telecommunications outlet/connector
- DD – Distribution device
- – Fiber Cabling (optional)

Typical Module Wiring Configuration

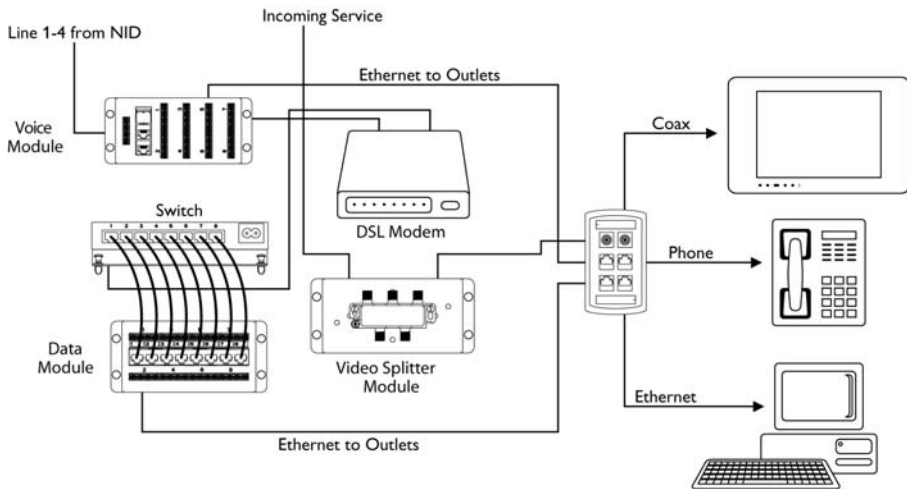

4. Trouble Shooting

The switch can be easily monitored through panel indicators to assist in identifying problems. This section describes common problems you may encounter and where you can find possible solutions.

- **Diagnosing LED Indicators**

If the link indicator does not light up after making a connection check to see if the network interface (e.g., a network adapter card on the attached device), network cable, or switch port is defective. Be sure the cable is plugged into both the switch and corresponding device. Verify that the proper cable type is used and its length does not exceed specified limits.

- **Power**

If the power indicator does not turn on when the power cord is plugged in, you may have a problem with the power outlet or power cord. However, if the switch powers off after it has been running, check for a loose power connection or power losses or surges at the power outlet. If you still cannot resolve the problem contact your local dealer for assistance.

- **Cabling**

RJ-45 Ports: Use unshielded twisted-pair (UTP) or shielded twisted-pair (STP) cable for RJ-45 connections: 100Ω Category 3,4,5,5e or 6 Cable for 10Mbps connections or 100Ω Category 5, 5e or 6 Cable for 100Mbps connections. Also be sure that the length of any twisted-pair connection does not exceed 100 meters (328 feet).

5. Technical Specification

This section provides the specifications of the 5-Port Switch:

Specification

Standards Compliance	IEEE 802.3 10BASE-T Ethernet, IEEE 802.3u 100BASE-TX Fast Ethernet IEEE802.3x Flow Control and Back-pressure
Connector	10/100TX: RJ-45
Protocol	CSMA/CD
Technology	Store-and-Forward switching architecture
Transfer Rate	14,880 pps Ethernet port, 148,800 pps per Fast Ethernet port
LED Indicators	Per Port: Link/Activity, Full/Collision, 100M Per Unit: Power
Network Cables	10Base-T: 2-pair UTP Cat. 3, 4, 5, 5e, 6 cable (100m), EIA/TIA-568 100-ohm STP (100m) 100Base-TX: 2-pair UTP Cat. 5, 5e,6 cable (100m), EIA/TIA-568 100-ohm STP (100m)
Dimensions	164mm x 100mm x 26mm (W x D x H)
MAC Address	1K Mac address table
Data Buffer	1Mbits
Operating Temperature	0°C to 45°C (32°F to 113°F)
Operating Humidity	10% to 90% (Non-condensing)
Power Supply	External power supply, DC 9V, 700mA
Power Consumption	4.2 Watt for 5-Port Switch
EMI & Safety	FCC Class B, CE & UL, cUL

Federal Communications Commission (FCC) Statement

This Equipment has been tested and found to comply with the limits for a Class B digital device, pursuant to Part 15 of FCC rules. These limits are designed to provide reasonable protection against harmful interference in a residential installation. This equipment generates, uses and can radiate radio frequency energy and, if not properly installed and used in accordance with the instruction, may cause harmful interference to radio communications. However, there is no guarantee that interference will not occur in a particular installation. If this equipment does cause harmful interference to radio or television reception, which can be determined by turning the equipment off and on, the user is encouraged to try to correct the interference by one or more of the following measures:

- Reorient or relocate the receiving antenna.
- Increase the separation between the equipment and receiver.
- Connect the equipment into an outlet on a circuit different from that to which the receiver is connected.
- Consult the dealer or an experienced radio/TV technician for help.

Warning: shielded-type power cord is required in order to meet FCC emission limits and also prevent interference to the nearby radio and television reception. It is essential that only the supplied power cord be used. Use only shielded cables to connect I/O device to this equipment. You are cautioned that changes or modifications not expressly approved by the party responsible for compliance could void your authority to operate the equipment.

p/n 100184-00 Rev. B