

STAR6000C6
JACK, CAT6 568A/B

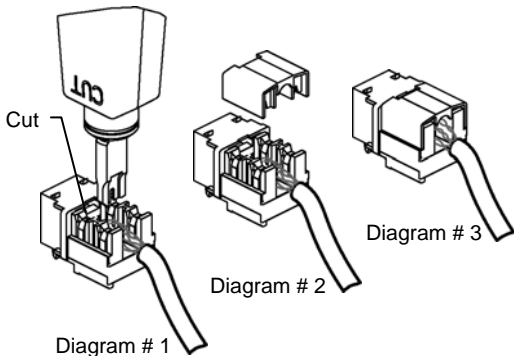

Step #1: Strip outer jacket of cable 1 ½" being careful not to nick the conductor insulation.

Step #2: Insert conductors into the color coded slots on IDC connectors. Do not untwist wire pairs more than 0.5" from termination point.

Step #3: Terminate conductors using impact tool. Trim excess conductors and discard. Install IDC cap (see Diagram #2 and #3).

Step #4: Diagram #4 shows Speedstar installation: Snap the bezel onto the connector and then snap the connector into faceplate from the back side.

